

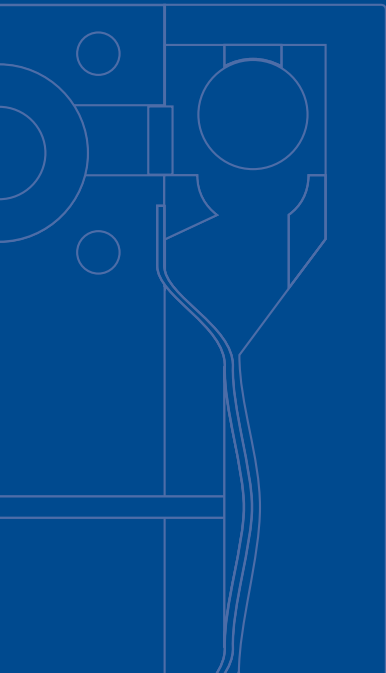

## VERDERAIR

Air Operated Double Diaphragm Pumps

**Increased productivity**  
**Reduced operational cost**  
**Improved working environment**



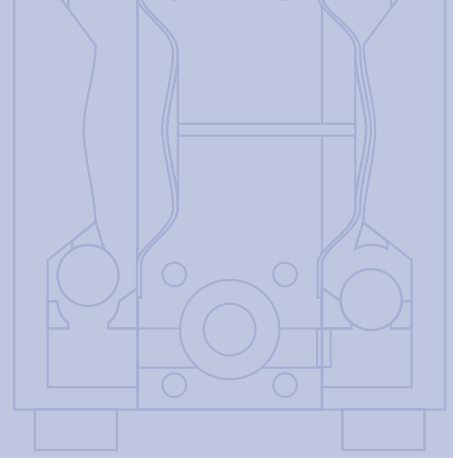

**Verderair**  
**The most efficient**  
**diaphragm pump**

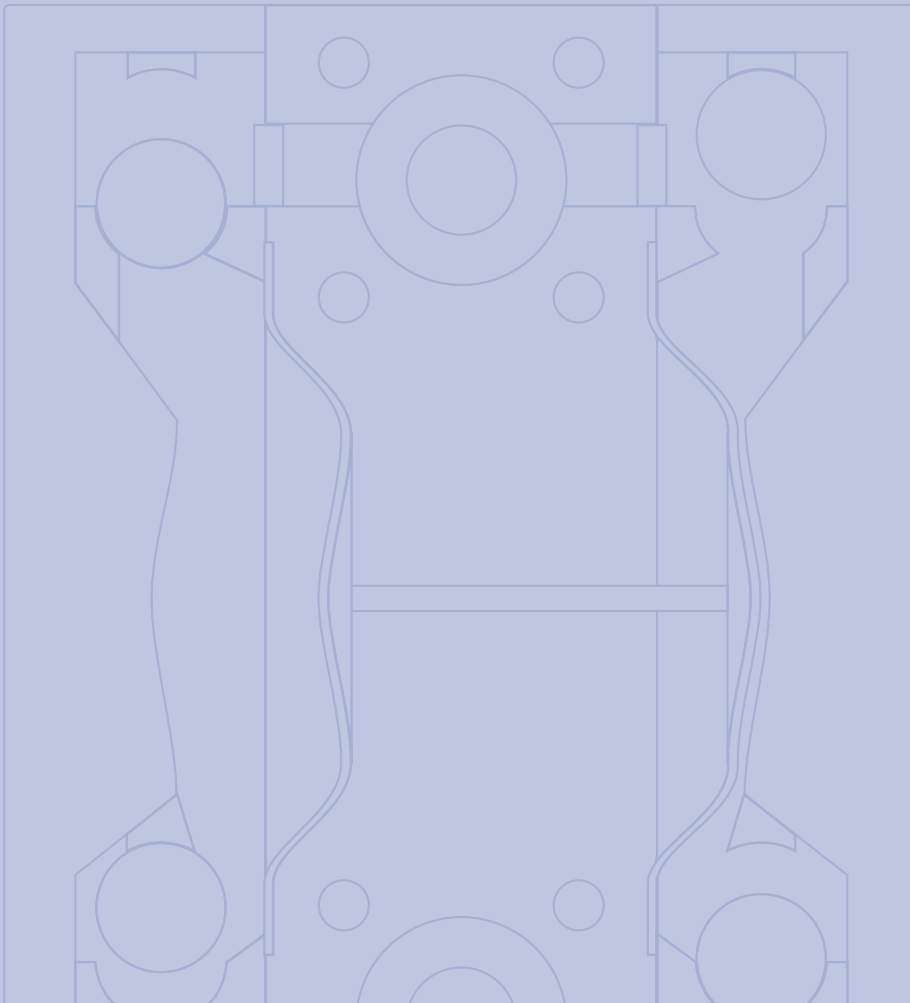

# Verderair

## Meet the most efficient double diaphragm pumps

*Verderair double diaphragm pumps have quick-acting air valves. The result is an increased productivity, reduced operational cost and improved working environment. This makes the Verderair range the most efficient double diaphragm pumps!*



### **Increased productivity**

#### **Higher flow rate, less maintenance**

Low "pressure drop" when the liquid passes the pump chamber. Smoother flow, increased efficiency pumping the liquid. The diaphragms have a special profile which is designed for an extremely long working life.

### **Reduced operational cost**

#### **Lower air consumption**

The quick-acting air valves are very fast in changing direction. No compressed air is entering the air chamber when the stroke is already completed. The used compressed air is removed from the pump with almost no restrictions. The compressed air is only used to move the liquid!

### **Improved working environment**

#### **Less noise**

By using all of the compressed air the pump makes less noise and the risk of freezing the exhaust is reduced.

# 50 years of more than 600,000

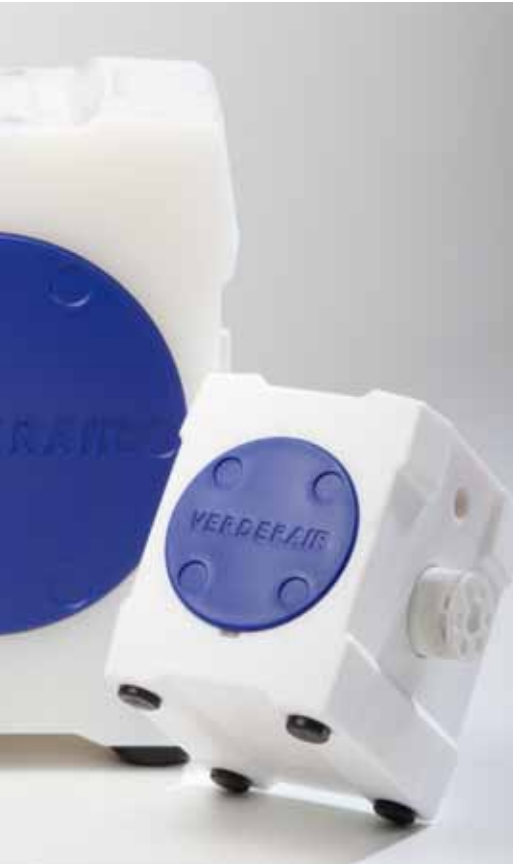

*With more than 50 years of experience in double diaphragm pump technology, and having sold more than 600.000 pumps all over the world Verder continuously improves, its technology to increase the efficiency of the Verderair pumps without using ancillary equipment. All other brands need ancillary equipment to enlarge the efficiency of the pump; needing no such equipment to achieve the best performance makes a Verderair the most efficient diaphragm pump.*

## **Special features of Verderair Pure**

- Solid design for perfect pressure holding & limited vibrations
- No metal wetted or external parts
- Possible to build pulsation dampener on top as integrated unit
- Access to valve seat and balls without disassembling



***The Verderair Pure***

# experience diaphragm pumps sold

## Some of Verderair's features

- Quick-acting air valve
- Easy to install
- Portable for multi-location use
- Easy to maintain
- Easy to operate
- Free of air lubrication
- Can run dry without damage  
(no dry-run protection needed)
- Can run against closed valves
- Non-stalling air valves
- Dry self priming
- No dynamic or pressure loaded seals



## Special features Verderair VA

- Bolted chambers for safe operation and easy maintenance
- Rugged, cast feed mounting holes for limited vibrations
- Plastic versions with inserts in pump chambers for holding optimum pressure



*The Verderair VA*



## Materials to choose from to meet your most severe process

*To meet your most severe process conditions, yet still having a trouble-free operation Verderair pumps have nine different material options for the valve seat, diaphragm & balls.*

*The combination of these high quality materials together with the choice of different pump materials give the optimum pump selection.*

**Acetal** Wide range of solvent resistant and withstands extreme fatigue. Good level of abrasion resistance. Electrical conductive. (Atex!).

**Santoprene** Good resistance to abrasive and chemical fluids. Santoprene is compatible with some solvents (e.g. Acetone, MEK), caustic solutions, dilute acids and alcohols.

**Teflon (PTFE)** Most compatible material for chemical applications, extremely resistant to corrosion and high temperatures, very low friction coefficient, non-adhesive.

**Thermoplastic polyester (Hytrel)** Good performance properties at lower temperatures and good resistance to abrasive fluids. Thermoplastic polyester is often a substitute for Buna-N.

**Fluorelastomers (Viton)** High heat resistance. Good resistance to aggressive chemicals including acids and some solvents. (e.g. xylene and mineral spirits). Good resistance to steam as well as animal, vegetable and petroleum oils. Resists unleaded fuels.



**NOTE** not all combinations are available. Please contact your local supplier.

**Geolast** Good abrasion resistance. Approximately same chemical compatibility as Buna-N.

**Polychloroprene (Neoprene)** Good chemical resistance, good performance with oils and many chemicals, good temperature resistance, outstanding physical toughness, outstanding resistance to damage caused by flexing and twisting. Resistance to abrasion is approximately 30% higher than Buna.

**EPDM** Good water and chemical resistance. Not for use with oils, greases and most solvents.

**BUNA** Good for petroleum-based fluids, water, oils, hydrocarbons and mild chemicals (e.g. mineral spirits).



# The heart of your pump: The air valve

*Verderair has proven to be the most efficient double diaphragm pump, mainly because of the engineered designs of the air valves of both series. The Verderair Pure pump is especially designed for working in severe environments. The air valve of this series is mounted in the inner of the pump. Therefore the pump efficiency is not influenced by atmospheric circumstances.*



The Verderair VA series are equipped with an air valve that has a modular cup and plate design. This air valve design is re-engineered based upon the existing model used successfully in Verderair pumps for many years.

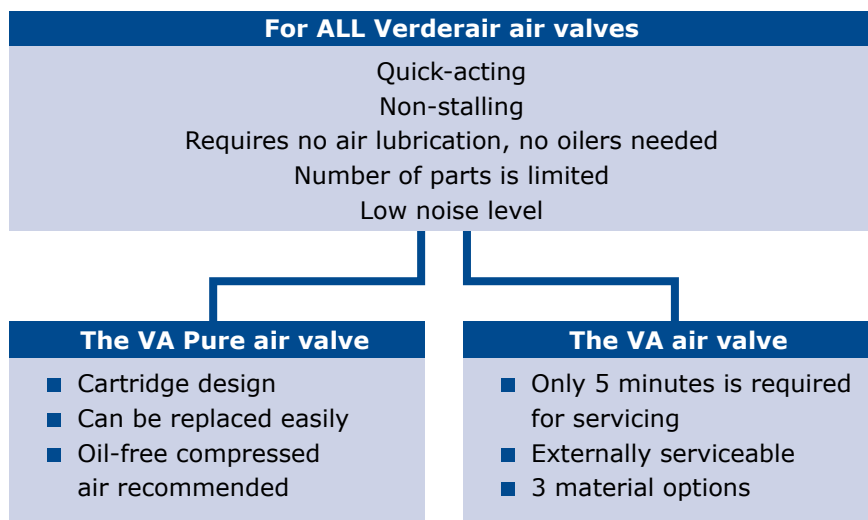



# Verderair Pure & Solid

The Verderair Pure double diaphragm pump is a new, robust, high-end series of double diaphragm pumps, produced from one-piece solid material. The Verderair Pure is designed for heavy-duty operation, also for harsh liquids and severe process conditions, such as operating in power plants and refineries.

The Verderair Pure has all the benefits of a Verderair double diaphragm pump such as increased productivity through a higher flow rate and reduced operational cost because of lower air consumption. Thanks to the efficient operation there is less maintenance, and an improved working environment is created because the pump makes less noise. The Verderair Pure is available in 4 wetted part materials; each pump being made from one solid piece of the purest and finest PTFE or PE.

- Applications**
- Chemicals transfer
  - Pharmaceutical industry
  - Solar power industry
  - Electronics-plating (Galvanics)
  - Refineries

## MATERIALS

### Polyethylene (PE)

Extremely abrasion resistant. Upto 7 times better than Polypropylene. Chemical resistance is comparable to Polypropylene.

### Conductive polyethylene

Similar properties to polypropylene but conductive for Atex applications.

### Teflon (PTFE)

Widest chemical compatibility, extreme corrosion resistance, very low frictional coefficient, non-adhesive, high heat resistance.

### Conductive teflon

Similar to PTFE, but electrical conductive (Atex!).

mm	VA-P08	VA-P10	VA-P15	VA-P25	VA-P40	VA-P50
Connections	8	10	15	25	40	50

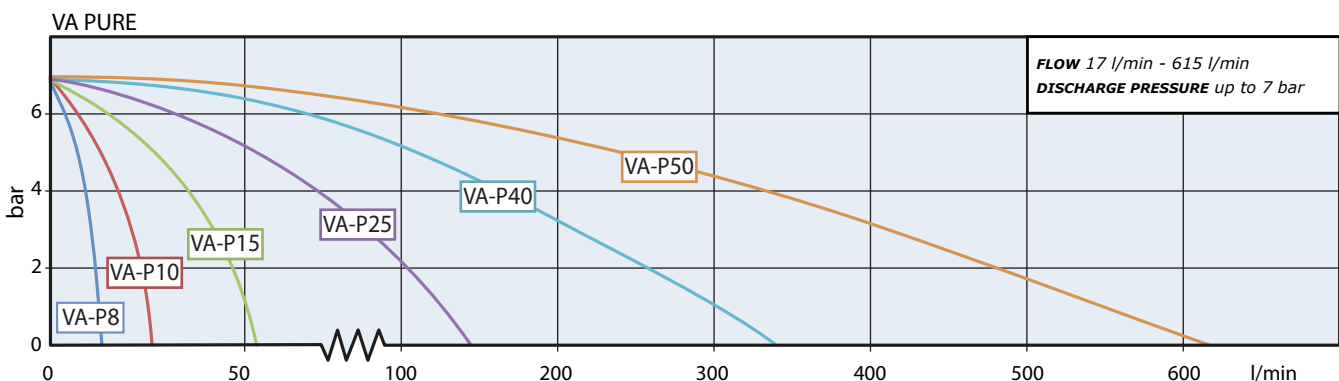





## Verderair Non-Metallic Series

Verderair non-metallic double diaphragm pumps are excellent pumps for use in a wide range of applications across many industries. Depending on your wishes, fluid and process specifications, the best solution is selected.

Verderair VA offers four non-metallic materials to choose from. Conductive Polypropylene and Acetal can be used in Atex rated zones. PVDF is the best choice for even the most chemically aggressive media.

### Applications

- Ink & paper
- Preparation of CIP solutions
- Surface finishing
- Car wash chemicals
- Water based paints

### MATERIALS

#### Polypropylene

Wide chemical compatibility. General Purpose. Limited temperature resistant.

#### Conductive polypropylene

Similar to standard Polypropylene but electrical conductive (Atex!).

#### PVDF (Kynar)

Conductive Polypropylene and Acetal can be used in Atex rated zones. PVDF is the best choice for even the most chemically aggressive media.

#### Acetal

Compatible with many solvent applications and can withstand extreme fatigue. Good resistance to abrasive media and is conductive for Atex applications.

mm	VA-08	VA-10	VA-15	VA-25	VA-40	VA-50	VA-80
Connections	8	10	15	25	40	50	80

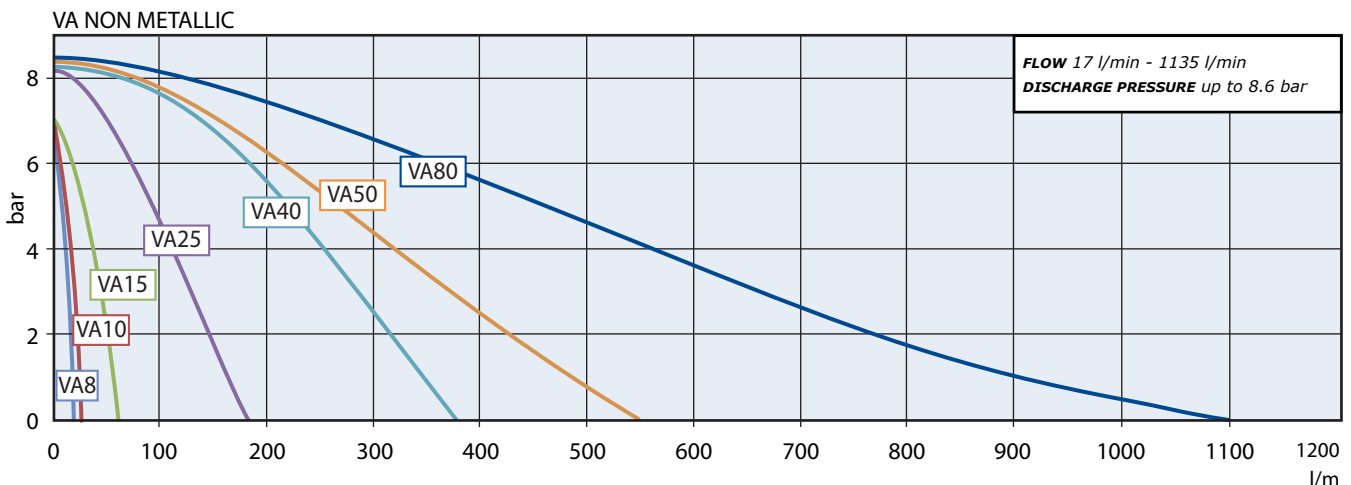



## Verderair Metallic Series

*If your process fluid is abrasive, a metallic double diaphragm pump will be an excellent choice. VA metallic diaphragm pumps are offered in Aluminium, Cast Iron and SS316. A Verderair can pump just about anything!*

### Applications

- Slaughterhouse waste
- Waste water
- Chemicals transfer
- Ceramic slurry
- Solvent based paints

### MATERIALS

#### Aluminium

General purpose. Good for solvent based coatings and inks. Resistant to mild chemicals.

#### Cast Iron

Highly abrasion resistant. Often used in paper, waste water industry and mining.

#### Stainless Steel 316

Resistant to most acids, bases and solvents. Can handle halogenated hydrocarbons. Good resistance to abrasive media.

mm	VA-20	VA-25	VA-40	VA-50	VA-80
Connections	20	25	40	50	80

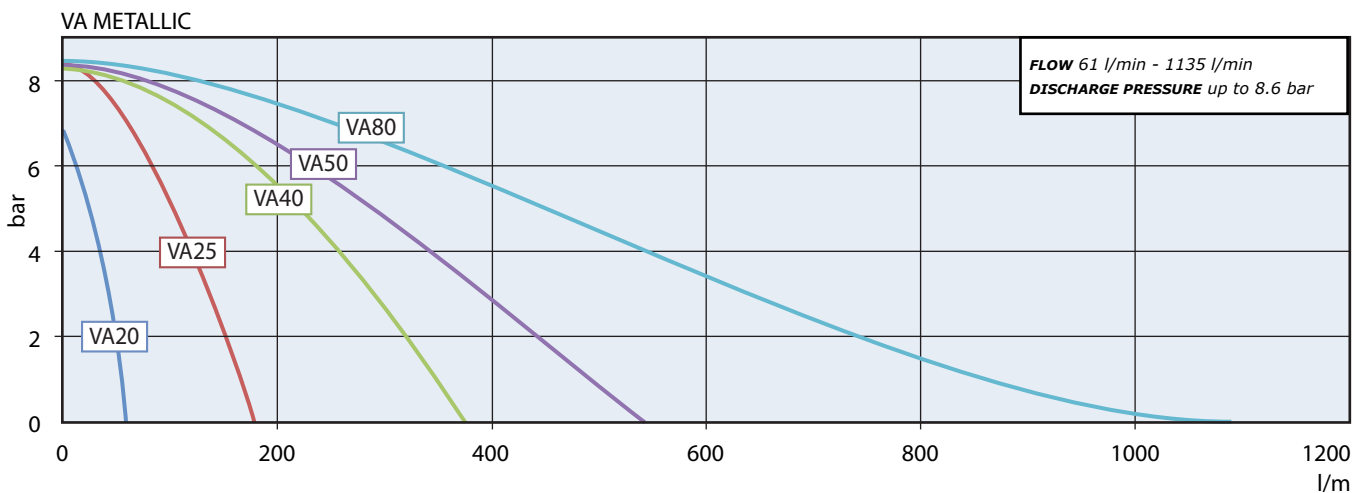



# Verderair Special Diaphragm Pumps

*The Verderair range includes a series of special pump models for specific applications relevant in many industries and applications areas.*

## **Verderair VA high pressure diaphragm pumps**

Double diaphragm pumps have a maximum air pressure rating of 8.4 bar. Verderair offer a series of high pressure pumps (up to 16 bar liquid pressure) with the same benefits and features as the reliable VA series of pumps.



Flow max. 530 l/min  
Pressure up to 16 bar

## **Verderair VA FDA diaphragm pumps**

Verderair FDA diaphragm pumps are specially constructed for processing applications in the food industry. Wetted materials are made of SS 316 Ra polish, 3.2 µm.



Flow max. 568 l/min  
Pressure up to 8 bar

## **Verderair VA hygienic diaphragm pumps**

The hygienic AODD pump series has a fast knock down system and can be cleaned with CIP and SIP processes. All wetted and non-wetted parts of these series are FDA and 3A compliant (SS 316 Ra polish, 0.8 µm). Ball valves are used as standard, but also flap valves for handling larger solids are available. The 3A compliant version is provided with a leak detection.



Flow max. 570 l/min  
Pressure up to 8 bar

## **Verderair VA drum pumps**

For the emptying of chemicals from small barrels, containers, canisters and drums (approx. 200l), (acid or lye) a double diaphragm pump is a very good alternative for a conventional rod drum pump. Pumps are delivered with standard suction tube.



Flow max. 61 l/min  
Pressure up to 7 bar

## **Verderair diaphragm pump with split manifold**

For the pumping of two liquids with one pump or for mixing two liquids with a 50-50 ratio.

Flow max. 2 x 30 l/min  
Pressure up to 7 bar

# Verderair Accessories

## **Pulsation dampeners**

Due to the function principle, double diaphragm pumps are generating a pulsating flow. To minimize this, Verder has created a line of pulsation dampeners based on the VA-Pure technology. The VA-P dampeners are active dampeners and achieve the best possible dampening effect to create an almost flat flow. They are available in the same sizes and materials as the VA-Pure pump range.



## **Barrier chamber (VA Pure only)**

To have the optimum protection against diaphragm failure, the VA-Pure series of pumps can be equipped with barrier chambers. A non conductive neutral fluid is kept between 2 diaphragms to separate the pump liquid and the atmosphere. When the diaphragm at the side of the pumped liquid fails, the neutral liquid is mixed with the pumped liquid. A sensor will detect the change in conductivity and the control unit will generate a signal which can start an alarm and/or stop the pump. In case of a failure of the air-side diaphragm, the neutral liquid will flow away and a capacitive sensor will detect this and the control unit will generate an alarm signal.

## **Diaphragm monitoring (VA and VA Pure)**

A capacitive sensor is installed in the muffler of the pump. When a diaphragm fails, liquid enters the air-side of the pump. The sensor will detect this and the control unit will generate a signal which can be used to start an alarm and/or stop the pump.

## **Remote operation (VA and VA-Pure)**

VA and VA-Pure pumps can be equipped to be controlled by a solenoid valve.

## **Stroke counting (VA and VA-pure)**

For VA pumps, a REED switch is mounted in the center block. This switch generates a pulse with every movement of the diaphragms. The output of this switch can be connected to a control box which counts the number of strokes the pump is making. For the VA-Pure pumps an inductive sensor is used instead of the REED switch.

## **Draining System (VA Pure only)**

The VA-Pure pumps of sizes 15-50 can be equipped with a draining system. This gives the possibility to drain the pump in line by operating a valve by hand or by a pneumatic signal.







## Verderair Sparekits

*The Verderair pump structure design was engineered to create long working life. However, regardless of quality, some parts are prone to wear and will need to be replaced. To ensure a minimum disruption to your production process, we advise you to keep the necessary spares in stock.*

Verderair offers spare part kits for wetted parts exposed to natural wear. Keeping sparekits on-site ensures your production process will never have downtime because of missing parts. In case of a pump break down it is advised to keep at least one spare parts kit on stock at your premises.

In case of emergencies Verderair can deliver from stock. Our fast delivery ensures your production process will be operational. Verderair spare parts are diaphragms, flap valves, valve seats and ball valves. For parts that are subject to wear we stock pre-assembled spare part kits.





## We also have a solution for your application!

*Verderair double diaphragm pumps can be used for drum transfer and for food transfers such as: chocolate, vinegar and dog food. Verderair pumps are also used for circulation of low/high viscosity inks, filling emptying process vessels, mixing tanks, dyes, wastewater and ceramics production. Verderair pumps are great pumps for pumping chemicals like acids, solvents, resins and latex. They are also suitable for the pharmaceutical industry; vegetable extracts, ointments, alcohols and sump waste.*

### [Beverage industry](#)

Yeast, diatomaceous earth, slurry, dregs, liquid hops, sugar, wine, fruit, corn syrup.

### [Pharmaceutical industry](#)

Vegetable extracts, tablet pastes, alcohols, filtering aids, ultra filtration, blood plasma.

### [Electronic industry](#)

Solvents, electroplating baths, carrier fluids for ultra-sonic washing, sulfuric nitric and acid washes, etching acids, acetone, polishing compound.

### [Paint and coatings](#)

Resins, solvents, wood preservative stain, concrete paints, titanium dioxide slurry, dispersions, varnish cleaning baths.

### [Food](#)

Brine, chocolate vinegar, molasses, dog & cat food, vegetable oil, honey, animal blood, CIP liquid preparation

### [Solar power industry](#)

Silicon dioxide slurry, HF, filter press.



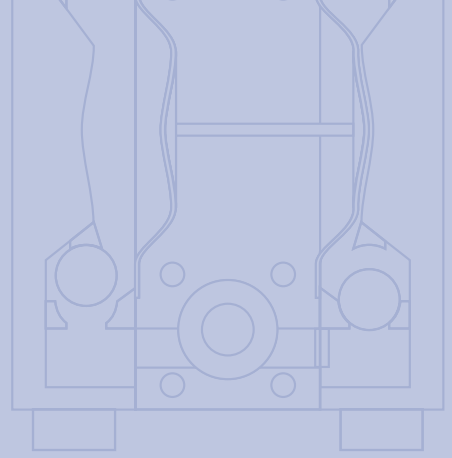

**Verderair**  
**The most efficient**  
**diaphragm pump**

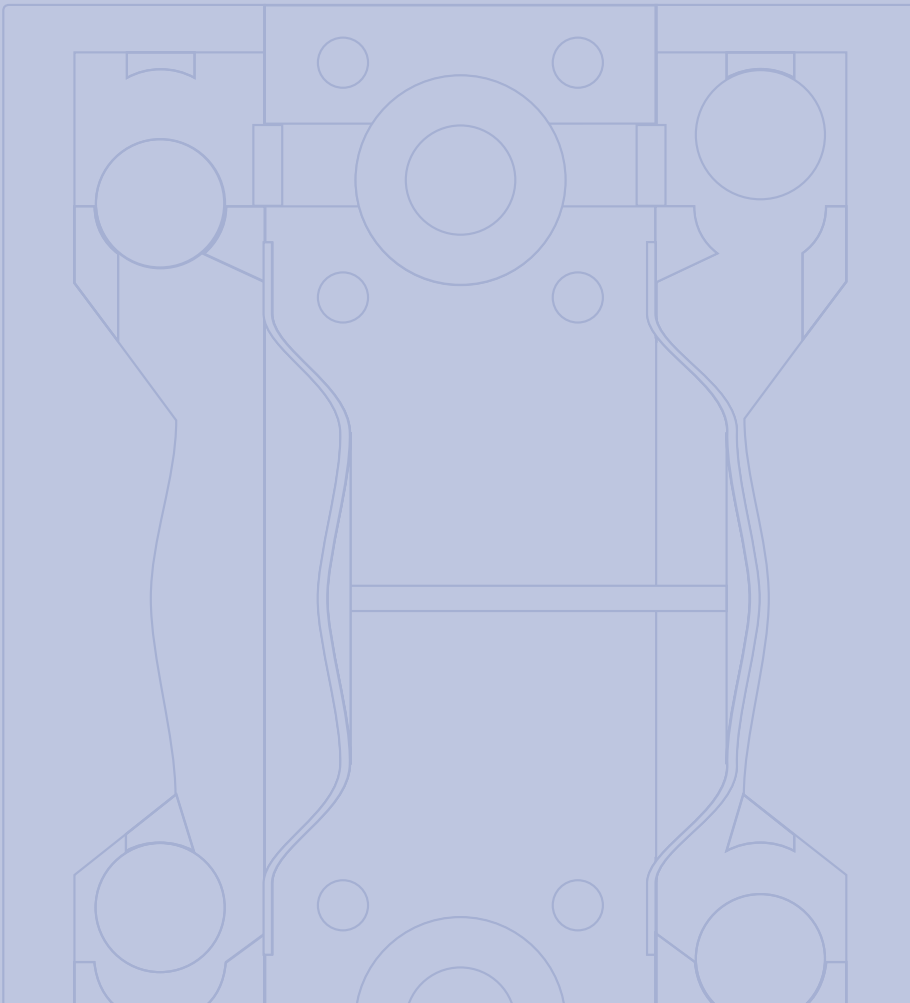



**Any questions?** You may still have questions and/or comments after reading this brochure. For more information, please visit our website [www.verderair.com](http://www.verderair.com) or contact your local supplier.

**VERDERAIR**

VA\_broch\_rev04-2012\_UK\_(uk)

**VERDERAIR**  
Kontichsesteenweg 17  
B-2630 Aartselaar  
Belgium

**TEL** +32 3 877 11 12  
**FAX** +32 3 877 05 75  
**MAIL** [export@verder.be](mailto:export@verder.be)  
**WEB** [www.verderair.com](http://www.verderair.com)

**AT** Wien **BE** Aartselaar **BG** Sofia **CH** Basel **CN** Shanghai **CZ** Praha **DE** Haan  
**DK** Rødovre **FR** Eragny s/Oise **GB** Castleford **HU** Budapest **IN** Pune **NL** Groningen/  
Vleuten **PL** Katowice **RO** Bucuresti/Sibiu **SK** Bratislava **TH** Bangkok **US** Macon  
(GA) **ZA** Northriding

